

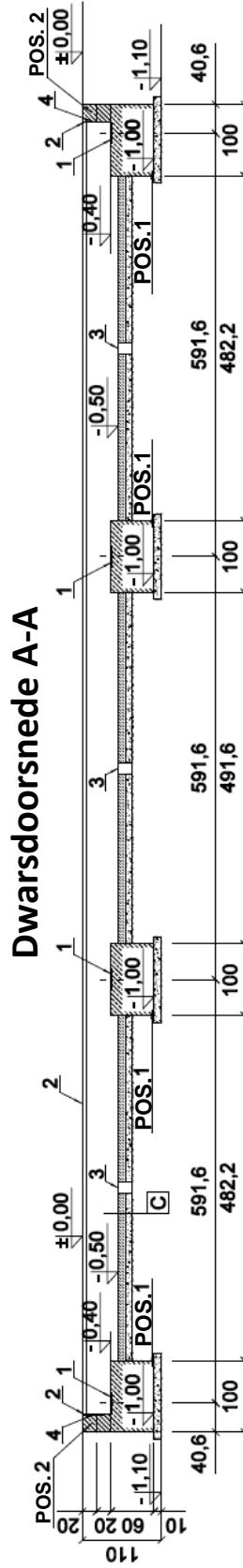

Maatschetsen
Modulaire Weegbrug
HM-WB

- 1. Projectie van fundering**
- 2. Verankeringsplaten**
- 3. Voetplaat**
- 4. Kroonplaat**
- 5. Aardingsplan weegbrug**

1. Projectie van fundering

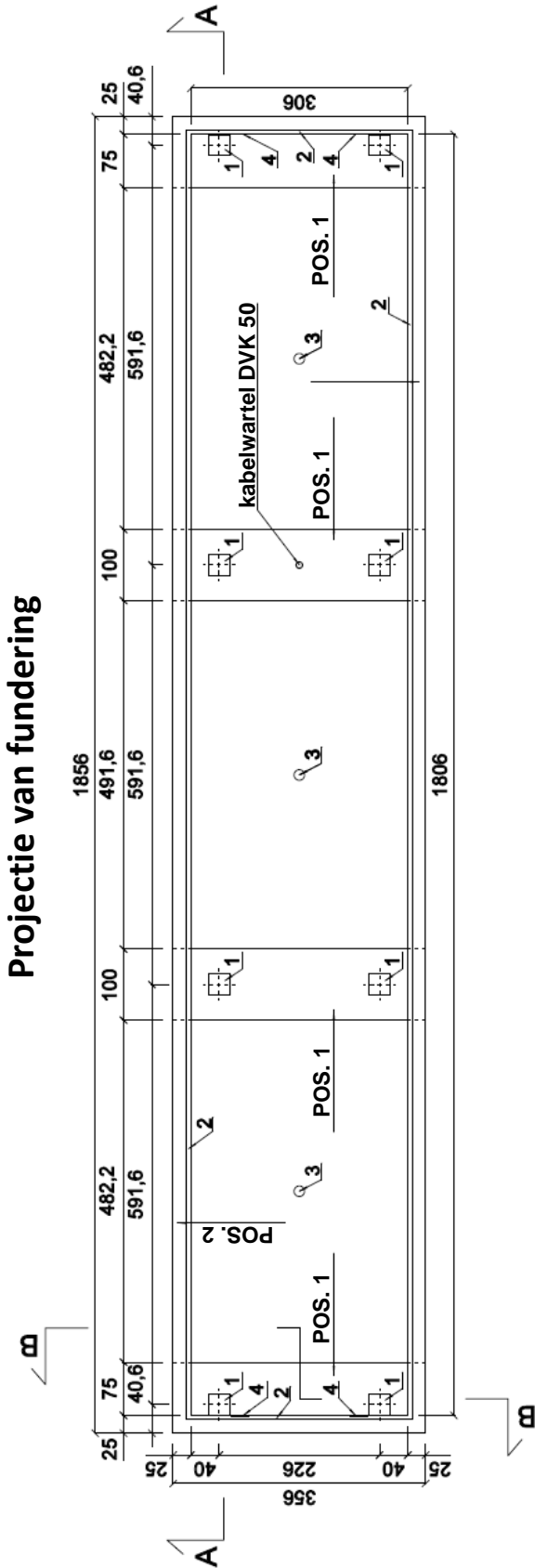

C	BEGANE GROND
	Beton C8/10 (B10)
	Verdicht zand

MATEN

Afmetingen in centimeters

LEGENDA

1. Staalplaat 300x300x12 mm, anker 2 Ø 12 mm - 8 st.
2. Staalprofiel L 60x60x4, anker Ø 12 mm
3. Afwateringsbuis Ø 160 mm (3 st.), aansluiten op put of regenwaterafvoersysteem
4. Spatplaat 240x220x8 mm (4 st.), gelast op stalen profiel L 60x60x4
5. Betonblok

Dwarsdoorsnede B-B

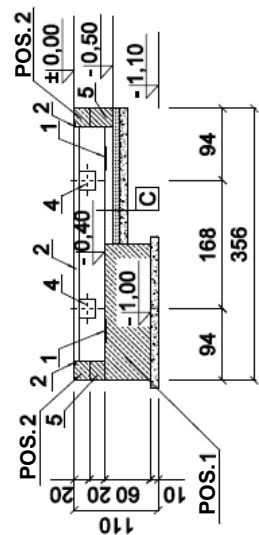

2. Verankeringsplaten

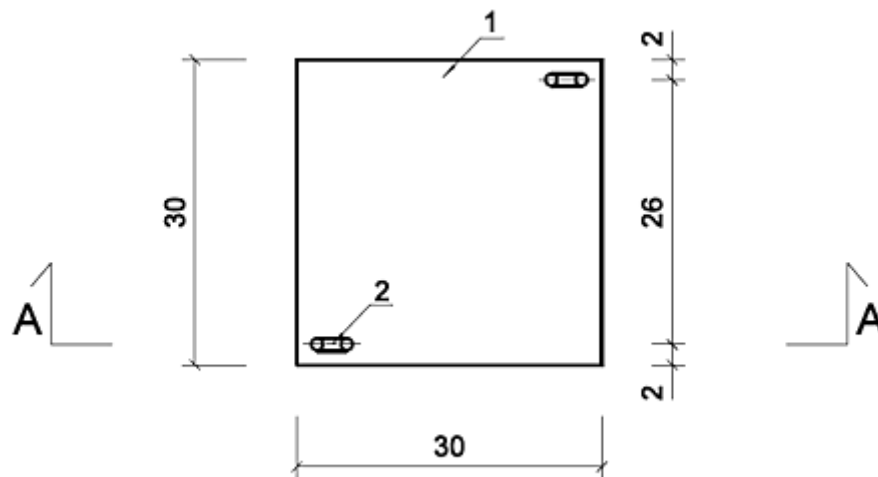

Dwarsdoorsnede

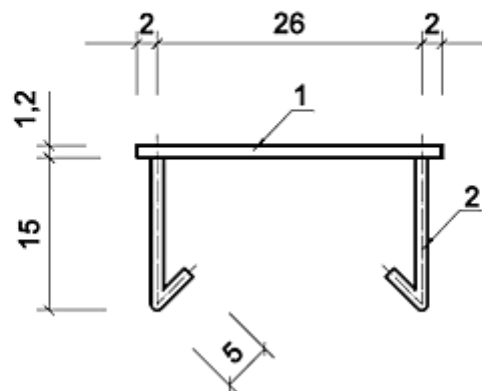

Afmetingen in cm

Legenda:

- 1 - staalplaat 300 x 300 x 12 mm - 8 stuks
- 2 - wapeningsstaal \varnothing 12 mm L=20 cm - 16 stuks

3. Voetplaat (POS. 1)

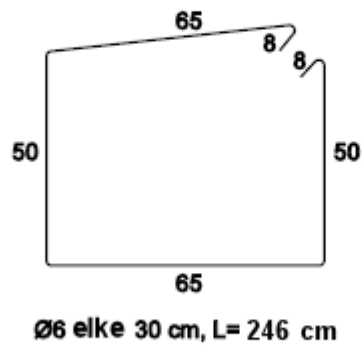
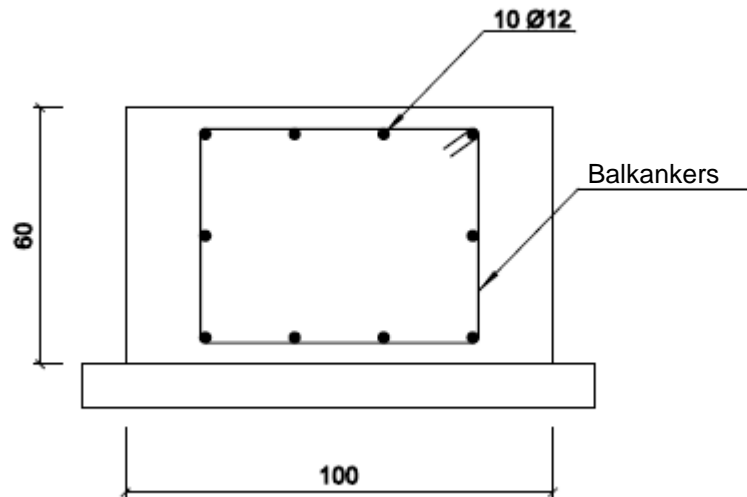

Afmetingen in cm

4. Kroonplaat (POS. 2)

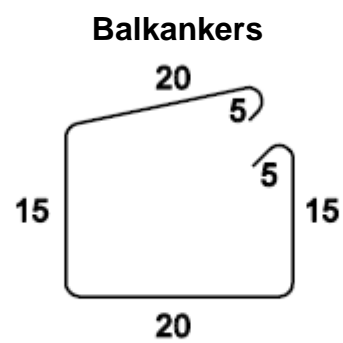
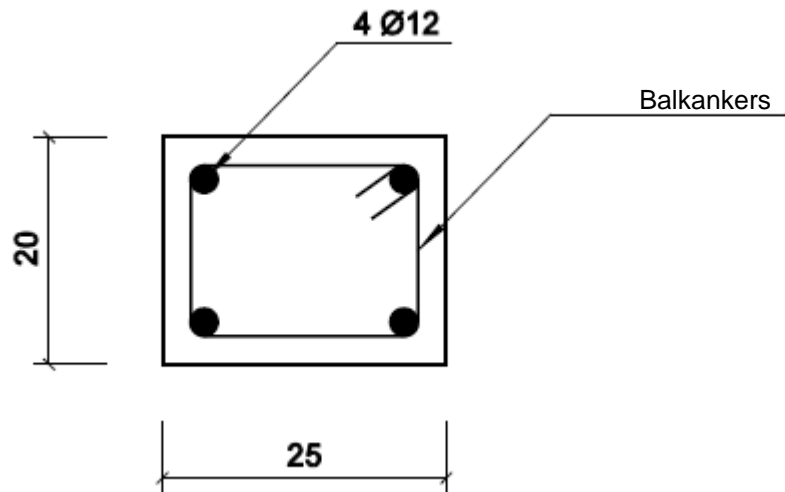

Ø6 elke 25 cm, L= 80 cm

Afmetingen in cm

5. Aardingsplan weegbrug

